

pottery barn kids

SPEED BOAT FULL BED

PRE-ASSEMBLY:

- Remove all parts and hardware from the box and lay out on a clear carpeted or scratch-free work surface. (The shipping box provides an ideal work surface), this will avoid damaging any parts during assembly. Do not dispose of any contents until assembly is completed to avoid accidentally discarding small parts or hardware.
- Two people recommended for ease of assembly.
- Use the parts and hardware lists to identify and separate each of the pieces included prior to starting assembly.
- The illustrations provided allow for easier assembly when used in conjunction with the assembly instructions.
- Note: Do not fully tighten all bolts until all parts are in place. Failure to follow these instructions may cause the bolts to misalign during assembly.
- If using power tools to aid in assembly please use caution. Power tools can damage hardware or split wood.

PARTS INCLUDED:

- A – Headboard (x1)
- B – Footboard (x1)
- C – Top tail (x1)
- D – Siderail (x1)
- E – Slat roll (x1)
- F – Side panel (x1)

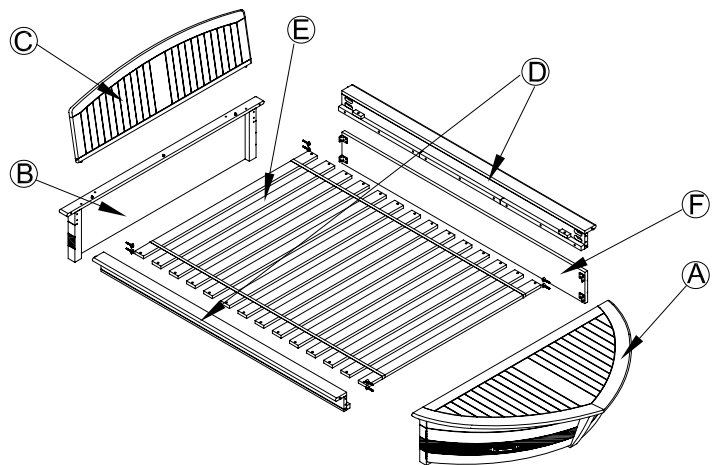

TOOLS REQUIRED:

Phillips head screwdriver (not included)

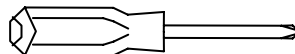

G – Ball tip Allen key (included)

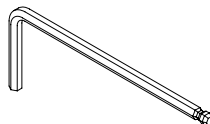

HARDWARE INCLUDED:

H – Allen Bolt 1/4"x50x13mm(x8)

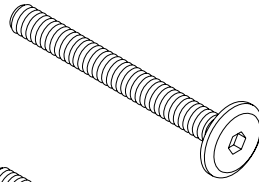

I – Allen Bolt 1/4"x28x13mm (x5)

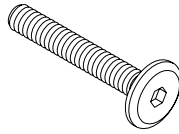

J – Spring washer 1/4"x10x2mm (x13)



K – Flat washer 1/4"x16x2mm (x13)



L – Half moon washer 1/4"x24x8mm (x8)

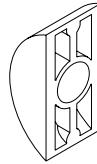

M – Phillips head screw 8x30mm (x28)

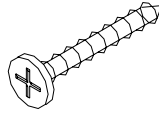

N – Phillips head screw 7x20mm (x24)

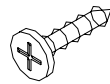

O – Mending plate 43x36x23mm (x4)

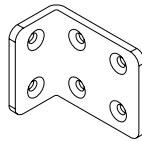

ASSEMBLY:

1. Place the Top Tail (C) on top of the footboard (B) as shown. Place a spring washer (J), then a flat washer (K) over an Allen Bolt 1/4"x28x13mm (I). Fasten bolt and washers up into bottom of Tail Top through footboard using Ball tip Allen Key (G) as shown. Repeat last 4 Allen bolts and washers.

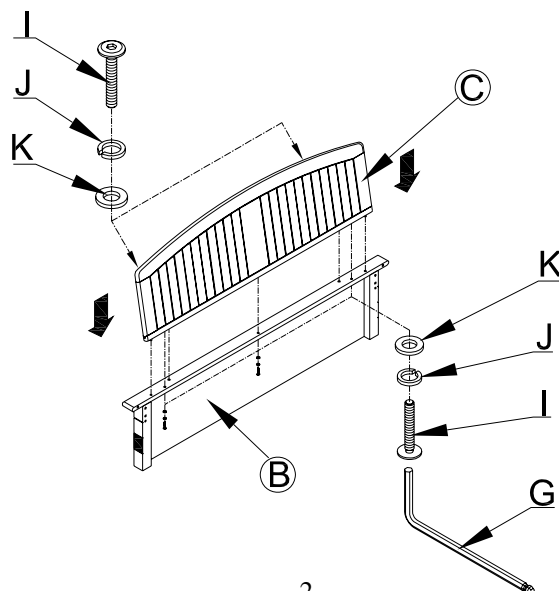

- Attach the Siderail (D) to the Headboard (A) and Footboard (B) using 8pcs Allen Bolt 1/4"x50x13mm (H) and 8pcs Spring washer (J) , 8pcs Flat washer (K) , 8pcs Half moon washer (L) as shown , tighten with Ball tip Allen Key (G).

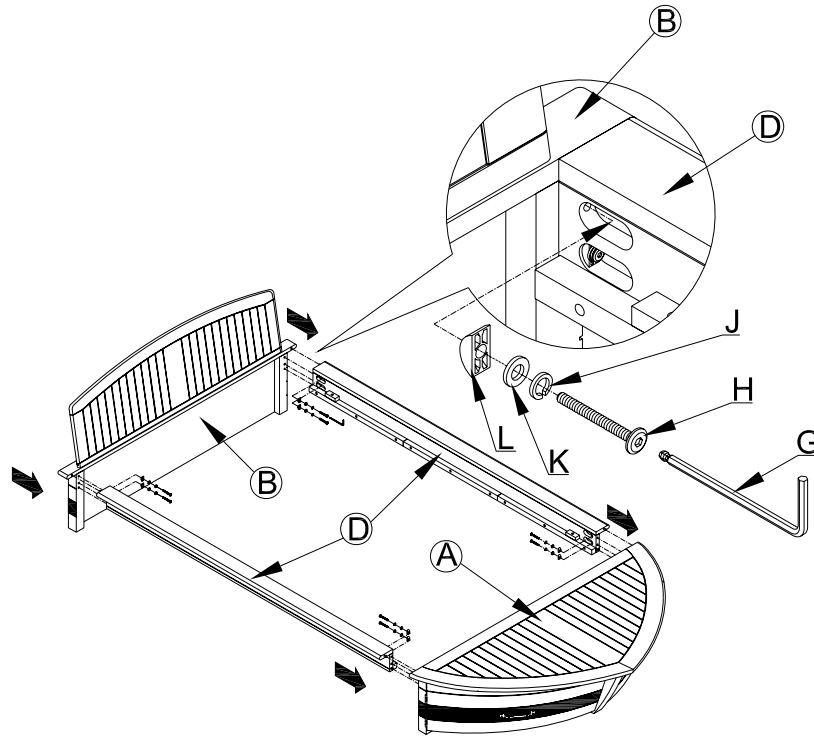

- Install the Mending plate 43x36x23mm (O) to the side panel (F) using 16pcs Phillips head screws 7x20mm (N), tighten with Phillips head screwdriver (not included).

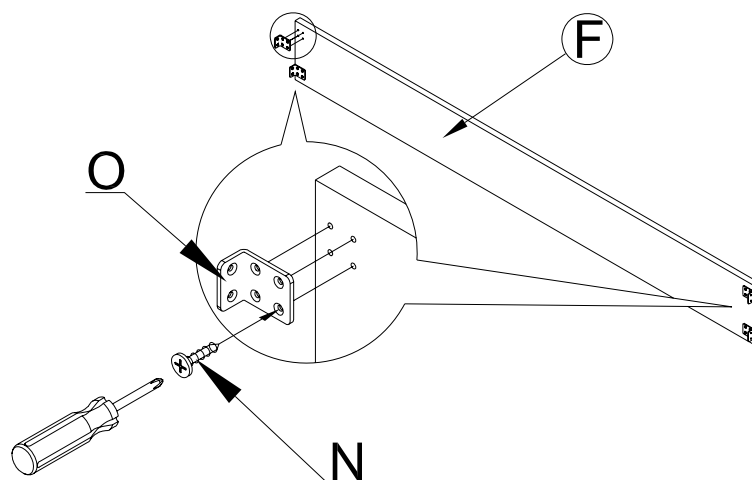

4. Attach the Side panel (F) to the Headboard (A) , under the Side rail (D)using 4pcs Phillips head screws 7x20mm (N) as shown. Repeat the same procedure with the Footboard (B).

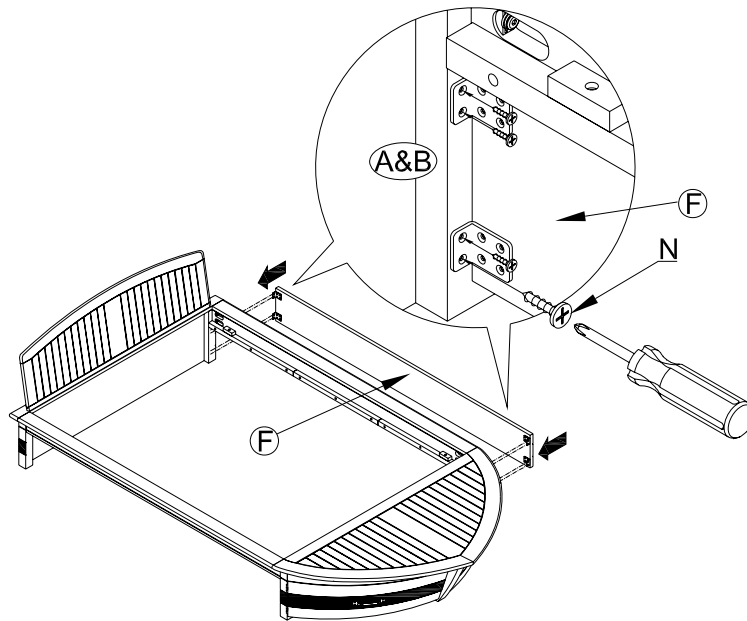

5. Lay the slat roll (E) in between the side rails (D) and use Phillips head screws 8x30mm (M) to fasten the slat to the siderail with Phillips head screwdriver.
6. Retighten all bolts screws to make sure all are tight and bed structure is rigid. It is recommended all bolts and screws be checked from time to time for safety.

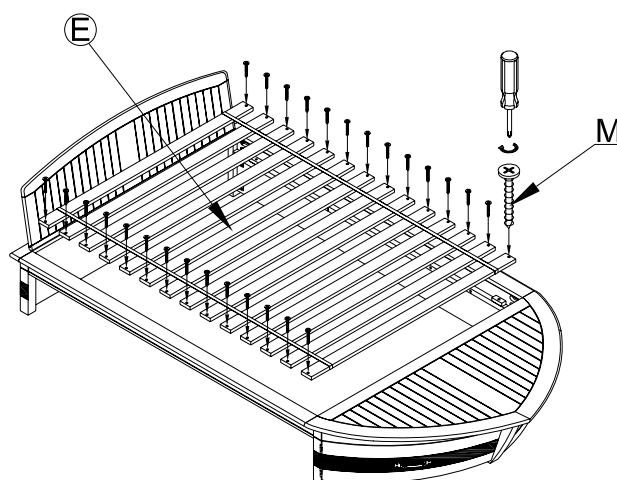

7. Slide assembled Trundle under the assembled bed.

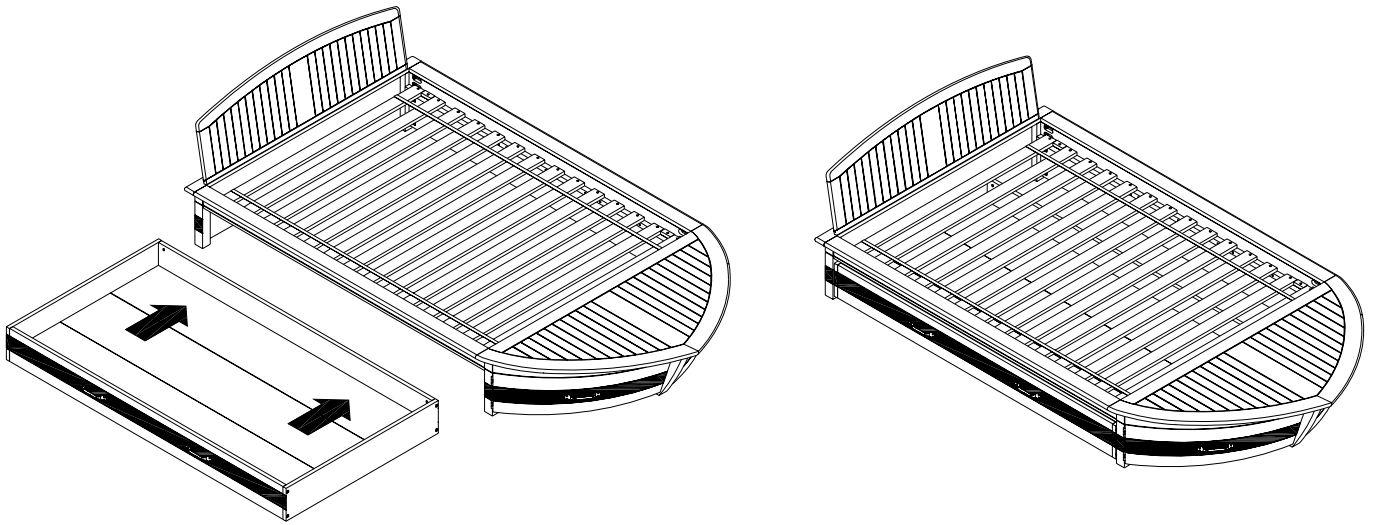

CARE INSTRUCTIONS:

- Dust often using a clean, soft, dry lint-free cloth.
- Blot spills immediately, and wipe with a clean, damp, cloth.
- We do not recommend the use of chemical cleansers, abrasives , or furniture polish on our lacquered finish.

Thank you for your purchase.

stores | catalog | www.potterybarnkids.com